



Cert. No. LRQ 0963008

ISO 9001

spirax sarco

TI-P164-02
ST Issue 6

Fig 1 and Fig 12 Brass and Bronze Strainers

Description

The Fig 1 and Fig 12 are brass and bronze screwed Y-type strainers. The standard stainless steel screen is 0.8 mm perforations. As options, other perforations and mesh sizes are available as well as monel screens. The strainer cap can be drilled and tapped for blowdown and drain valves if required.

Sizes and pipe connections

Fig 12 Brass $\frac{3}{8}$ " to 1", **Fig 12 Bronze** $\frac{1}{2}$ ", $\frac{3}{4}$ ", 1, 1 $\frac{1}{4}$ ", 1 $\frac{1}{2}$ ", 2" and 2 $\frac{1}{2}$ "
Fig 1 Bronze 3"
Screwed BSP (BS 21) or NPT

Optional extras

Strainer screens

Stainless steel screen	Perforations	1.6, 3.0 mm
	Mesh	40, 100, 200
Monel screen	Perforations	0.8, 3.0 mm
	Mesh	100

Blowdown or drain valve connections

The cap can be drilled to the following sizes to enable a blowdown or drain valve to be fitted at extra cost.

Strainer size	Blowdown valve	Drain valve
$\frac{3}{8}$ " and $\frac{1}{2}$ "	$\frac{1}{4}$ "	$\frac{1}{4}$ "
$\frac{3}{4}$ " and 1"	$\frac{1}{2}$ "	$\frac{1}{2}$ "
1 $\frac{1}{4}$ " and 1 $\frac{1}{2}$ "	1"	$\frac{3}{4}$ "
2" and 2 $\frac{1}{2}$ "	1 $\frac{1}{4}$ "	$\frac{3}{4}$ "
3"	1 $\frac{1}{2}$ "	$\frac{3}{4}$ "

Limiting conditions

Strainer	Fig 12	Fig 1
Body design conditions	PN25	PN16
PMA - Maximum allowable pressure	25 bar g	16 bar g
TMA - Maximum allowable temperature	210°C	250°C
Minimum operating temperature	-198°C	0°C
Designed for a maximum cold hydraulic test pressure of:	38 bar g	24 bar g

Operating range

Fig 12 Strainer

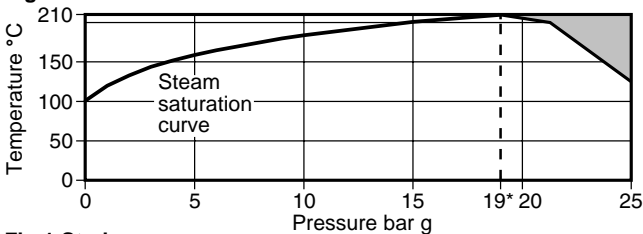
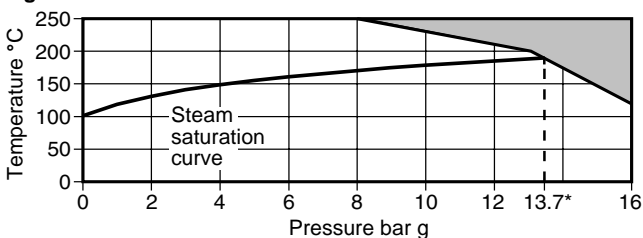

Fig 1 Strainer



■ The product must not be used in this region.

*PMO - Maximum operating pressure for saturated steam.

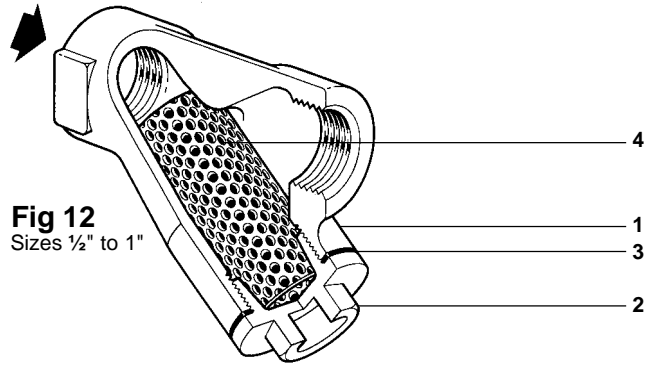

Fig 12
Sizes $\frac{1}{2}$ " to 1"

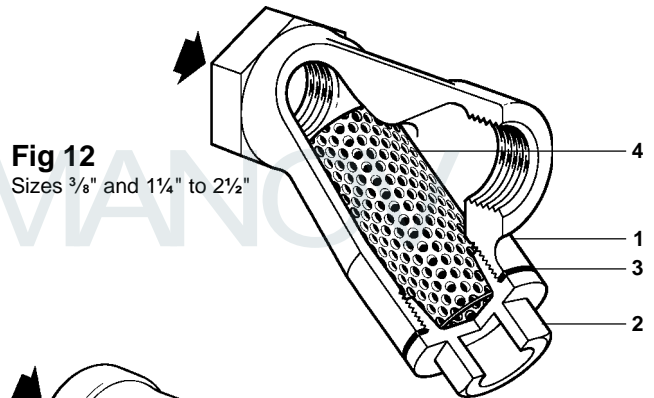

Fig 12
Sizes $\frac{3}{8}$ " and 1 $\frac{1}{4}$ " to 2 $\frac{1}{2}$ "

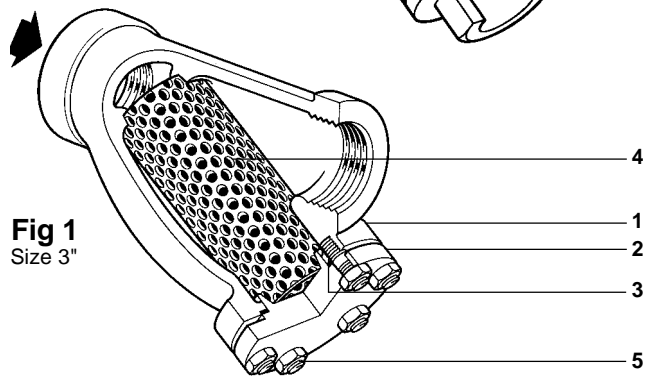

Fig 1
Size 3"

Materials

No. Part	Material	
1 Body	$\frac{3}{8}$ "	Brass EN 12165 CW617N
	$\frac{1}{2}$ " to 3"	Bronze EN 1982 CC491K
2 Cap	$\frac{3}{8}$ " to 2 $\frac{1}{2}$ "	Brass EN 12165 CW617N
	3"	Bronze EN 1982 CC491K
3 Cap gasket	Reinforced exfoliated graphite	
4 Strainer screen	Stainless steel ASTM A240 316 L	
5 Cap studs 3"	Carbon steel BS 970 216 M28	
Cap nuts 3"	Carbon steel BS 1768 Gr. 1	

Certification

The product is available with material certification to EN 10204 2.2 for the body and cap. **Note:** All certification/inspection requirements must be stated at the time of order placement.

Dimensions/weights (approximate) in mm and kg

Brass body

Size	A	B	C	D	Screening area cm ²	Weight
3/8"	69	50	80	24 A/F	27	0.45

Bronze body

1/2"	72	54	85	30 A/F	27	0.55
3/4"	89	64	110	36 A/F	43	0.70
1"	104	72	130	46 A/F	73	1.00
1 1/4"	138	100	170	52 A/F	135	1.60
1 1/2"	150	110	190	60 A/F	164	2.10
2"	178	133	212	79 A/F	251	4.80
2 1/2"	210	152	240	98 A/F	327	7.70
3"	270	190	305	124 A/F	361	17.70

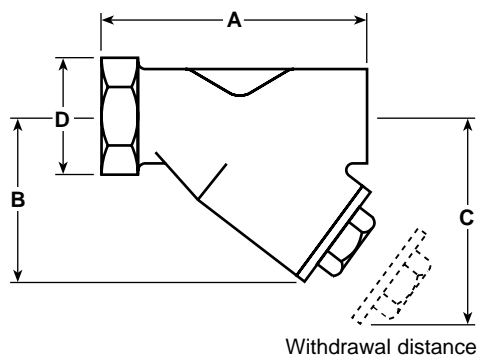

Safety information

For full details see the Installation and Maintenance Instructions (IM-S60-17) supplied with the product.

Pressure

Before attempting any maintenance of the strainer, consider what is or may have been in the pipeline. Ensure that any pressure is isolated and safely vented to atmospheric pressure before attempting to maintain the strainer. This is easily achieved by fitting Spirax Sarco depressurisation valves type DV (see separate literature for details). Do not assume that the system is depressurised even when a pressure gauge indicates zero.

Temperature

Allow time for temperature to normalise after isolation to avoid the danger of burns and consider whether protective clothing (including safety glasses) is required.

Warning: The strainer cap gasket contains a thin stainless steel support ring, which may cause physical injury if it is not handled and disposed of carefully.

Installation

For full details see the Installation and Maintenance Instructions (IM-S60-17) supplied with the product.

The strainer should be installed in the direction of flow, as indicated on the body. On applications involving steam or gases the pocket should be in the horizontal plane. On liquid systems the pocket should point downwards. Suitable isolation valves must be installed to allow for safe maintenance and trap replacement. Remove all protective caps prior to installation. Open isolation valves slowly until normal operating conditions are achieved. Check for leaks and correct operation.

Maintenance

For full details see the Installation and Maintenance Instructions (IM-S60-17) supplied with the product.

Maintenance can be completed with the strainer in the pipeline, once the safety procedures have been observed. It is recommended that a new gasket is used whenever maintenance is undertaken.

Disposal

The product is recyclable. No ecological hazard is anticipated with disposal of this product, providing due care is taken.

How to order

Example: 1 off Spirax Sarco 1 1/2" Fig 12 bronze strainer with screwed BSP connections and stainless steel screen having 0.8 mm perforations.

K_V values

Size	3/8"	1/2"	3/4"	1"	1 1/4"	1 1/2"	2"	2 1/2"	3"
Perforations 0.8, 1.6 and 3 mm	2.6	3	6.2	11.3	26	41	68	98	115
Mesh 40 and 100	2.6	3	6.2	11.3	26	41	68	98	115
Mesh 200	2.6	3	6.2	9.3	21	33	55	78	93

For conversion: C_V (UK) = K_V x 0.963 C_V (US) = K_V x 1.156

Spare parts

The spare parts available are shown in solid outline. Parts drawn in broken line are not supplied as spares.

Available spares

Strainer screen. (state material, size of perforation or mesh and size of strainer)	4
Cap gasket (packet of 3)	3

How to order spares

Always order spares by using the description given in the column headed 'Available spares' and state the size and type of strainer and perforations or mesh required.

Example: 1 - Stainless steel strainer screen having 0.8 mm perforations for a 3/4" Spirax Sarco Fig 12 Strainer.

Fig 12

Sizes 1/2" to 1"

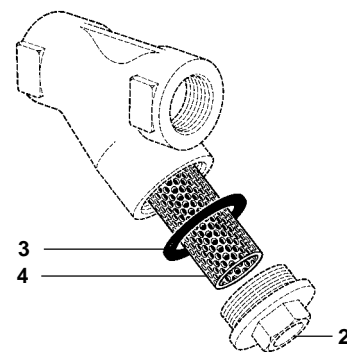

Fig 12

Sizes 3/8" and 1 1/4" to 2 1/2"

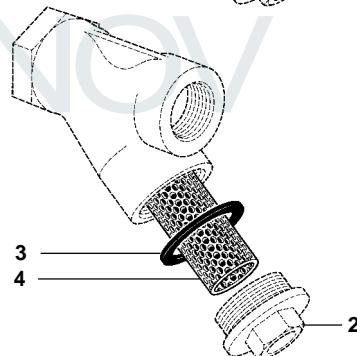
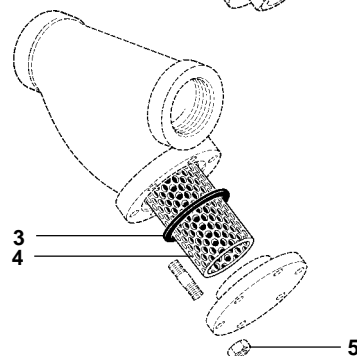

Fig 1

Size 3"



Recommended tightening torques

Item	Size	Qty	or mm	N m	
2	3/8", 1/2"	1	22 A/F	M28	35 - 40
	3/4"	1	27 A/F	M32	42 - 48
	1"	1	27 A/F	M42	70 - 80
	1 1/4"	1	41 A/F	M56	124 - 144
	1 1/2"	1	41 A/F	M60	164 - 184
	2"	1	55 A/F	M72	234 - 264
5	2 1/2"	1	55 A/F	3/4" - 16 UNS	300 - 330
	3"	6	3/4" A/F 7/16" UNF x 1 1/2" (38 mm)		50 - 55